

---

# Instruction Manual



**Retrofit: LED High Bay Lamp**

**Model NO: 45167W**

## Product specification

- Beam Angle: 120°
- Color Rendering Index(CRI):70
- Weight:11.2(Kg)
- Heat sink : Extruded Aluminum
- Base: Plug
- Dimension: (mm)

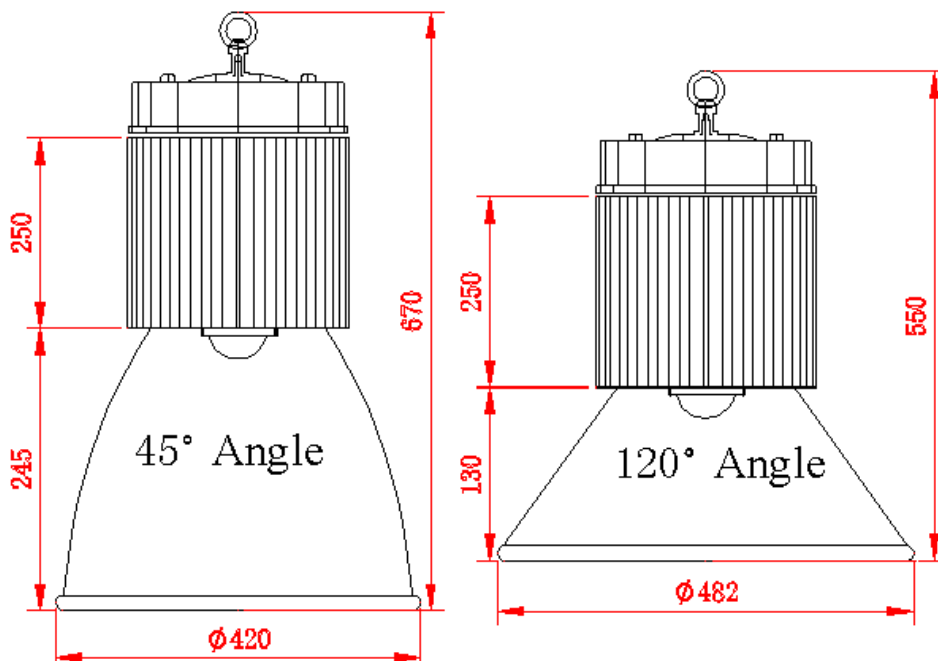

- Replaced By: 500W Halogen Bulb
- Dimmability: Not Dimmable

## Electrical Specification

- Input Voltage: AC100~277V
- Power Consumption: 200W
- Power Factor: 0.96

## Optical Specification

- Chip manufacturer: Bridgelux 45mil
- Luminous Flux: 21907.8Lm
- Correlated Color Temp: 4000-4100K

- Illuminance (center point)

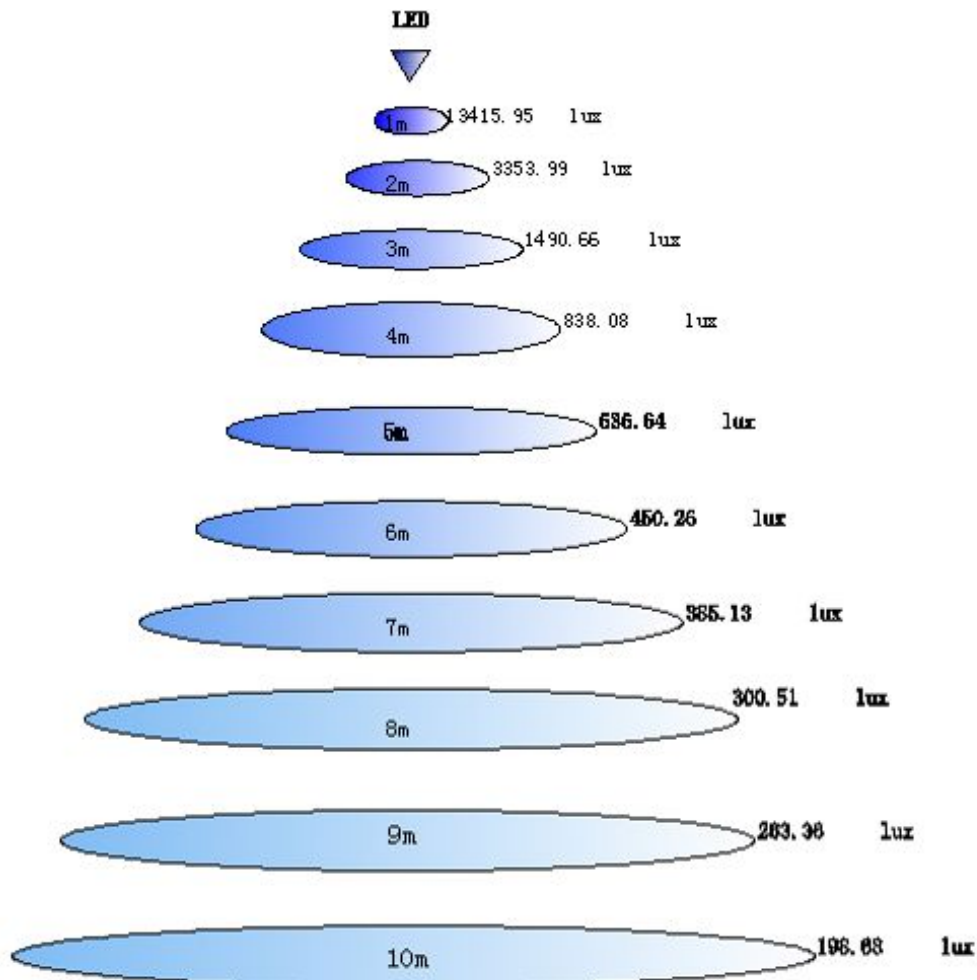

## Warranty

- See Website Details page for information.

## Environment Specification

- Operating Temp:-20°C-45°C
- Environmental Humidity:10%-90%
- IP Protection Degree: IP65

## Regulation:

- Certification: UL CB TUV CE ROHS

## Characteristics:

- a. Long lifespan
- b. Notable energy-saving
- c. Convenient installation
- d. Healthy Ray, NO UV or IR radiation
- e. High CRI
- f. High safety Factor
- g. Extensive Ranges of Applications
- h. Efficient constant current driver
- i. Single integrated high power LED light source

## Installation instructions

1.

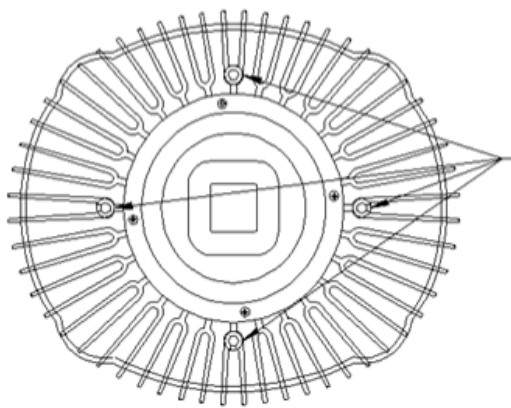

Loosen the four screws

2.

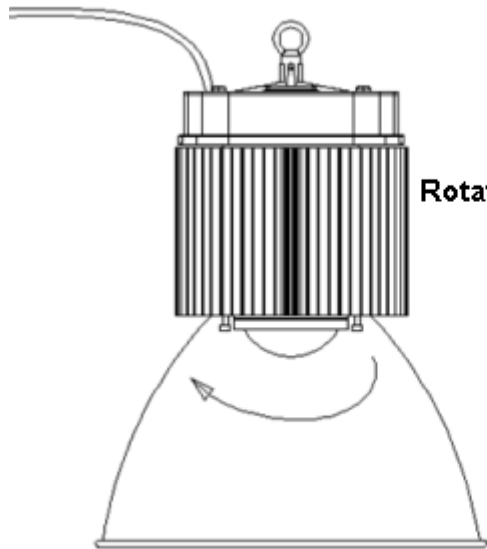

Rotate the reflector clockwise

3.

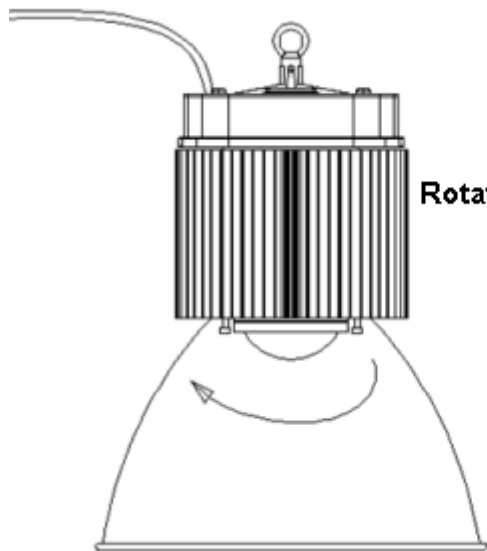

Rotate the reflector clockwise

4.

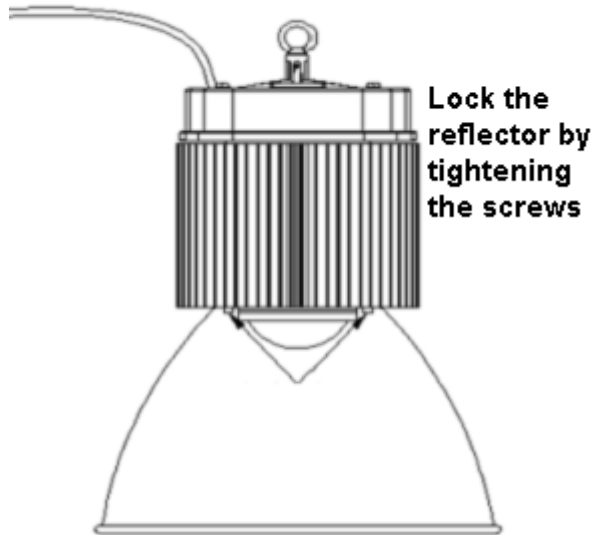

5.

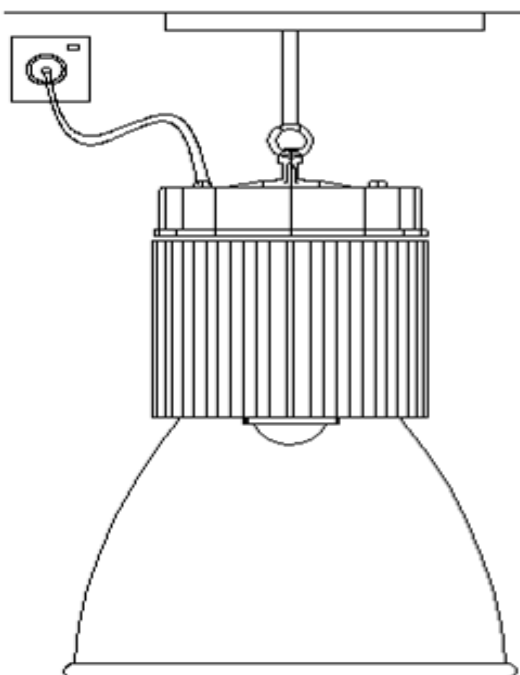

## Applications:

Apply to the workshop, the factory, toll station, gas stations, large supermarket, the exhibition hall, the stadium and other places of need illumine.

## Packaging:

- **Radiator packaging information:**

Quantity: 1 Pcs radiator per carton.

Packing material: K353K+EPE+PE

Gross weight: 11.6Kg/Carton.

Net weight: 10.6Kg/Carton.

Carton size: L300X W 300XH448 ( mm).

- **Packaging method:**

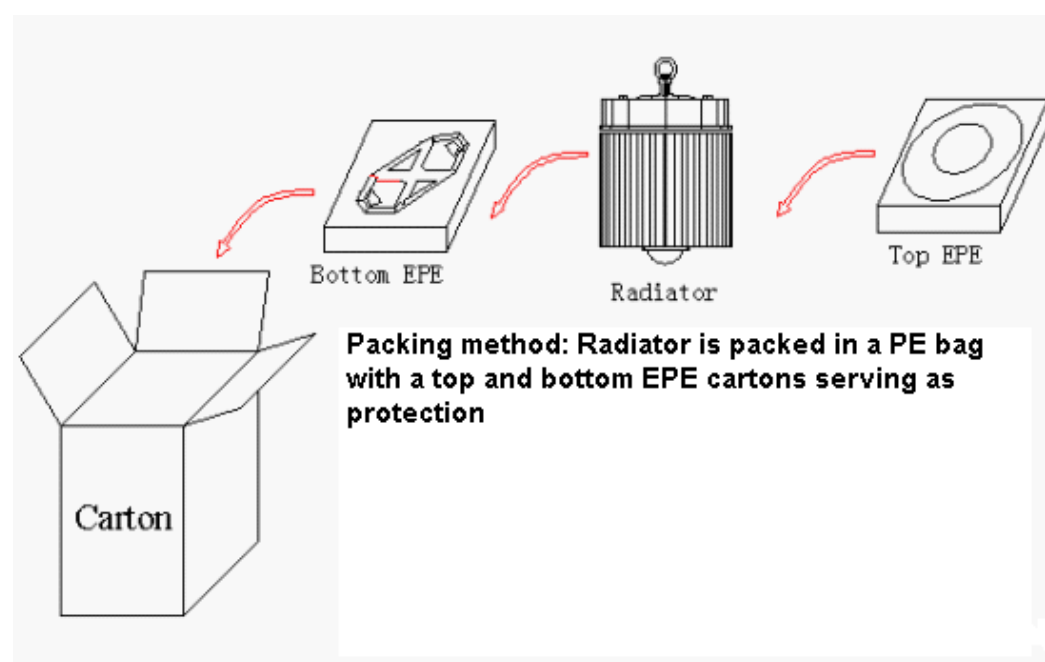

- **Reflector packaging information:**

Quantity: 10 Pcs **reflector** per carton.

Packing material: K353K+EPE+PE

Gross weight: 7Kg/Carton.

Net weight: 6Kg/Carton.

Carton size: L504X W 504XH350 ( mm).

- **Packaging method:**

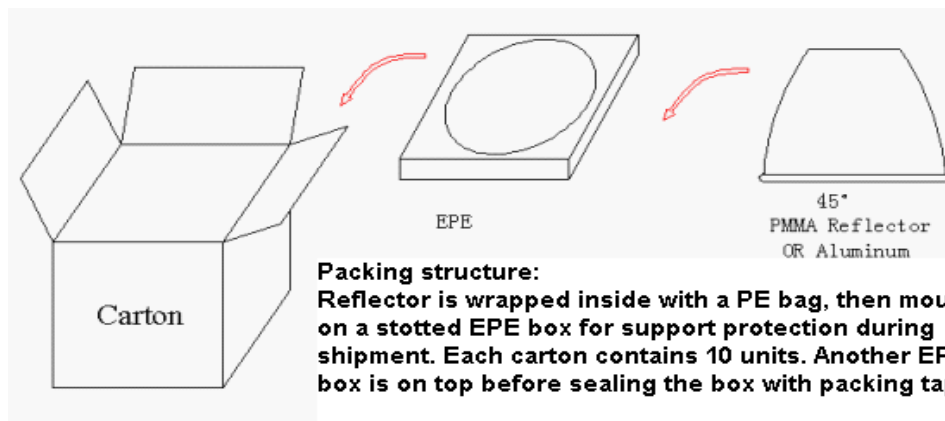





---

## Use Notice

***Warning for applications:***

1. No ballast is needed. Any ballast should be removed before installation!
2. The socket temperature peak is 60°, do not touch the aluminum or any part while working.
3. The product cannot be discarded into garbage can directly, necessary measures should be done for full recycling.
4. Ensure that installed firmly

**Website: [www.LEDLight.com](http://www.LEDLight.com)**

**Email: [sales@LEDLight.com](mailto:sales@LEDLight.com)**

**Tel: (001) - 877 - 283 - 5060**

**Fax: (001) - 602 - 861 - 4088**