

Instruction Manual

NAME: DMX512 decoder
MODEL: 75864



Product Description

DMX512 decoder adopts the advanced micro control unit, It can receive the DMX-512 standard digital control signal which is internationally widely used. It changes the signal into PWM control signal to actuate the LED lamp. It can also connect the DMX digital console to change the light or each dynamic effect.

External Dimension

Picture:



Packing size:



Technical Parameters

Working temperature	-20-60°C
Supply voltage	12V~24V
Output	3 channels
Connecting mode	common anode
External dimension	L127*W42*H33 (mm)
Packing size	L135*W55*H40 (mm)
Net weight	140g
Gross weight	160g
Output gray	256 levels (RGB each)
Output current	<6A(each channel)
Output power	12V:<216W, 24V:<532W
Frequency of RF remote control	433.9MHz
Frequency of PWM signal output	5.2KHz

Interface Specifications

DMX input/output interface:



Adopt Standard RJ45 network cable port.

Address code and set feature service interface:

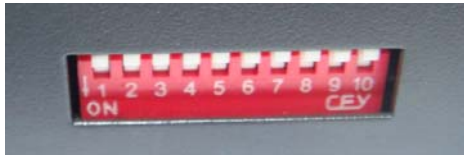

Adopt 10-bit side of the dial-type DIP switch.

Power and Payload interface:

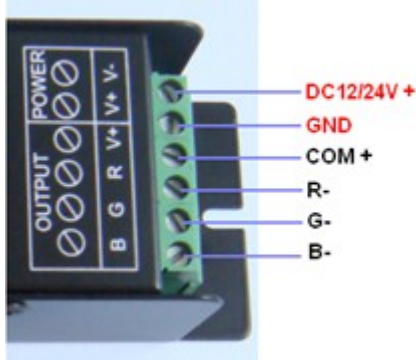

Adopt male and female connector with screw.

Direction for use

This product is in compliance with DMX512 protocol, compatible autoindex addressing and manual establishment address.

Each universal DMX controller takes up 3 DMX addresses. It adopts 2 ways (autoindex addressing and code switch) to set up the address. When adopting the autoindex addressing, all switches are “off” status. When adopting the code switch to set up address, the 10th bit(FUN) is “off” status, and other 9 bits are binary value code switch which are used to set up the DMX starting address code. The first bit is the lowest order bit, and the ninth is the highest order bit. That can set up 511 address codes. The DMX starting address code is equal to the sum of 1st to 9th bit. If move down one bit of code switch (“ON” set “1”), you can get the placevalue of this bit. If move up (set “0”), the placevalue is 0. For example: if you want to set up DMX starting address code for 73, you should move down the 7th, 4th, and 1st bit of code switch for “1”, and others for “0”. Then the placevalue’s sum of 1st to 9th bit is $64+8+1$. That is to say, the DMX512 starting address code is 73. (The correspondence dials code position is as follows)

To choose the channel from the Dial in-line Package (DIP) Switch:

Number	1	2	3	4	5	6	7	8	9	10
Weight number	1	2	4	8	16	32	64	128	256	FUN

1. Example 1:

Like figure 1, to set up the DMX starting address code for 37, should move down the 6th, 3th, 1st bit for “1”, others for “0”. Then the placevalue’s sum of 1st to 9th bit is $32+4+1$, as is for 37.

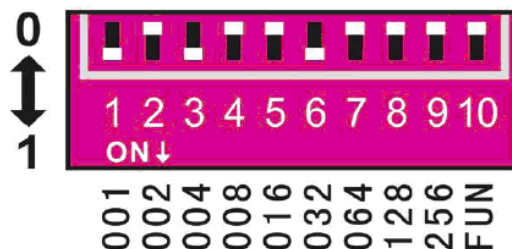

Figure 1

2. Example 2:

Like figure 2, to set up the DMX starting address code for 328, should move down the 9th, 7th, 4th bit for “1”,

others for "0". Then the placevalue's sum of 1st to 9th bit is 256+64+8, as is for 328.

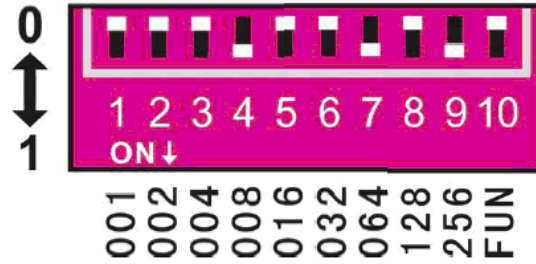

Figure 2

The function outside of the DMX

1. Control with DIP switch

1) Test function:

The DIP switch's 10th bit is "FUN", for built-in function key. When "FUN"="OFF", is for DMX decoder function. This is used to adopt DMX signal. When "FUN"="ON", the test function like figure 3:

1-9 switch OFF: black

Switch 1=ON: red

Switch 2=ON: green

Switch 3=ON: blue

Switch 4=ON: yellow

Switch 5=ON: purple

Switch 6=ON: cyan

Switch 7=ON: white

Switch 8=ON: Seven-color jumpy changing (8 grades of speeds are available)

Switch 9=ON: All-color gradual changing (8 grades of speeds are available)

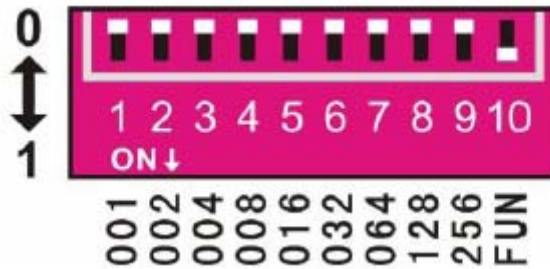

Figure 3

2) Speed choice of jumpy changing and gradual changing's effect:

In test function, when switch 8=ON, is for seven-color jumpy changing effect. When switch 9=ON, is for seven-color gradual changing effect. 8 grades of speeds are available for each effect:

1-7 switch OFF: 0 grades of speeds

Switch 1=ON: 1 grade of speeds

Switch 2=ON: 2 grades of speeds

Switch 3=ON: 3 grades of speeds

Switch 4=ON: 4 grades of speeds

Switch 5=ON: 5 grades of speeds

Switch 6=ON: 6 grades of speeds

Switch 7=ON: 7 grades of speeds (maximum speed)

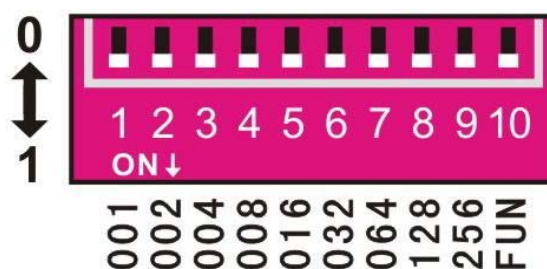

Figure 4



As figure 4, when all switches are “ON” at the same time, the more value is taken as final. The state of decoder is gradual changing of test function. Its variable speed is 7. In addition, when signal indicator (green) blinks slowly, it runs the built-in program effectiveness of decoder. When the decoder receives the DMX signal, signal indicator will flash rapidly.

Typical Applications

1. Be used as a DMX512 decoder:

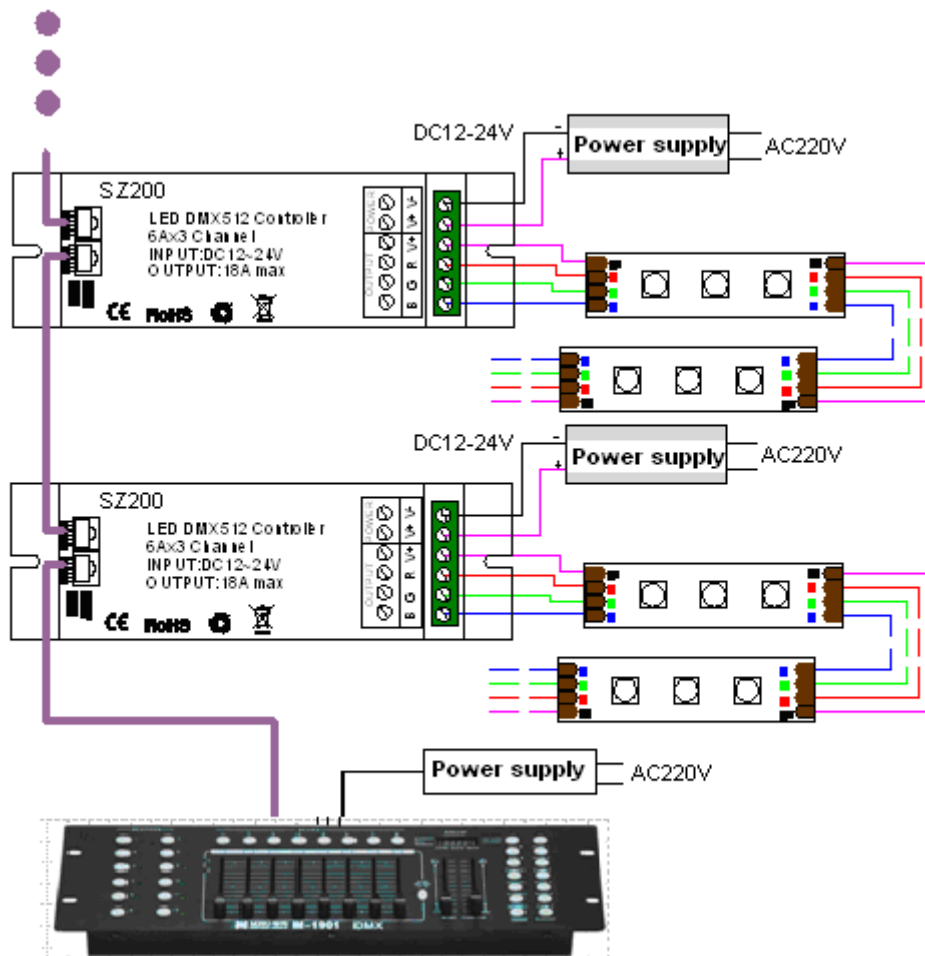

2. Be used as a common PWM controller without remote control:

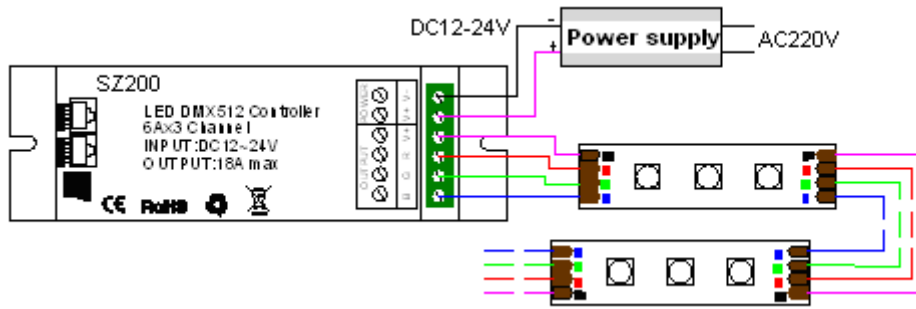

Notes:

The input and output voltage(220V and 12V) is for your reference only, it depends on the actual voltage in your area and adaptor.

! Notes

1. Supply voltage of this product is DC12V~24V, never connect to others or AC220V.
2. Lead wire should be connected correctly according to grade that connecting diagram offers.
3. This product is not to overload;

Common Problems

Problems	Possible cause	Solution
1. Lamp does not light after power	Power cord is not properly connected, or there is not output switching power supply	Connect the power cord properly or replay the power
	Lamp power cord is not connected or short circuit	Connected lighting power cord
2. After connecting some of the load the controller does not work	The connected load is too large, so that it has burned in some of the components of the controller	Replace parts of components or replace the controller