



Instruction Manual



Retrofit: LED Tube Lamps

Model No.	LEDs	Voltage	Frequency	Current	Watts	Color	Tube Length
55634W	DIP 300	AC 100-277V	50Hz/60Hz	.18A-.06A	17W	Daylight White	4 Feet
55634DW	DIP 300	AC 100-277V	50Hz/60Hz	.18A-.06A	17W	Natural White	4 Feet
78687W	SMD 300	AC 100-277V	50Hz/60Hz	.18A-.06A	17W	Daylight White	4 Feet
78687DW	SMD 300	AC 100-277V	50Hz/60Hz	.18A-.06A	17W	Natural White	4 Feet







SECTION 1 - General Information

Models were only evaluated for factory installation to end luminary, or to end Retrofit Luminary, intended to replace a fluorescent lamp where it is necessary to modify the luminary. These LED Tube Lamps intended to retrofit maximum four lamps, surface mount, or Type IC recessed mount fluorescent luminaries that use straight tubular 4-foot lamps.

- These lamps should be installed by a licensed electrician.
- These lamps work on line voltage and require all ballasts to be removed before the bulb is to be installed in the luminary.
- These lamps are to be used in indoor dry or damp location only. Not suitable for wet location luminary.
- These lamps are not to be used with a light dimmer. The starters need to be bypassed. Always contact ground lead to luminary where applicable.
- Please contact your authorized dealer, distributor, or if you have any questions not addressed in these instructions. Please see contact information in last page LEDLight.com.

SECTION2- WARNING

	WARNING RISK OF ELECTRICAL SHOCK DO NOT OPEN	
WARNING: To reduce the risk of electrical shock, do not remove cover and caps No user-serviceable parts inside. Refer servicing to qualified service personnel.		

 WARNING : TO REDUCE THE RISK OF FIRE OR ELECTRICAL SHOCK,
DO NOT EXPOSE THIS APPARATUS TO RAIN OR MOISTURE
LUMINAIRE CONVERSION, RETROFIT

FOR USE ONLY WITH FLUORESCENT LUMINAIRES IDENTIFIED IN MANUFACTURER' S INSTRUCTIONS

THIS PRODUCT MUST BE INSTALLED IN ACCORDANCE WITH THE APPLICABLE INSTALLATION CODE BY A PERSON FAMILIAR WITH THE CONSTRUCTION AND OPERATION OF THE PRODUCT AND THE HAZARDS INVOLVED.

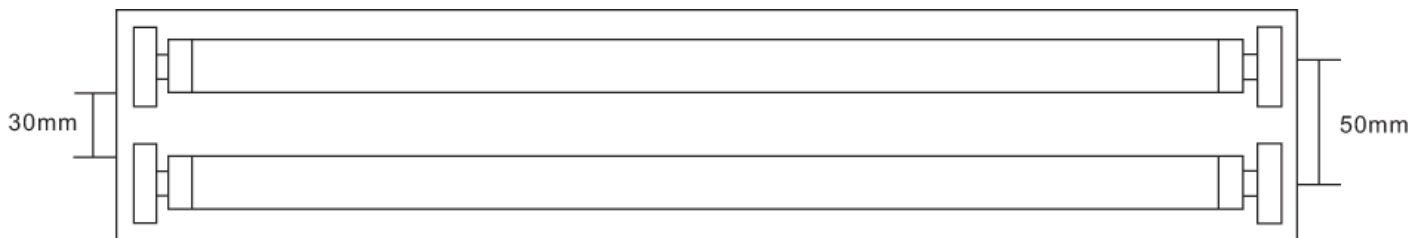
These lamps can be used in any standard T8 lamp luminaire, allowing for its minimum spacing requirements.



Minimum distance
between lamps

Minimum distance
between lamps pin
sockets

WARNING: Risk of fire or electric shock. Reflector kit installation requires knowledge of fluorescent lighting luminaires' electrical systems. If not qualified, do not attempt installation. Contact a qualified electrician.

WARNING: Risk of fire or electric shock. The electrical rating of this product is AC120V-277V, the installer must determine whether they have AC100V-277V at the luminaire before installation.

WARNING: Risk of fire or electric shock. Install this kit only in the luminaires that has the construction features and dimensions shown in the photographs and/or drawings.

WARNING: Risk of fire or electric shock. Luminaires wiring, ballasts, or other electrical parts may be damaged when drilling for installation of reflectory kit hardware. Check for enclosed wiring and components.

WARNING: To prevent wiring damage or abrasion, do not expose wiring to edges of sheet metal or other sharp objects.

WARNING: Risk of fire or electric shock. Do not use this retrofit kit in luminaires employing shunted bi-pin lamp holders.

WARNING: THE RETROFIT ASSEMBLY IS ACCEPTED AS A COMPONENT OF A FLUORESCENT LUMINAIRE WHERE THE SUITABILITY OF THE COMBINATION SHALL BE DETERMINED BY CSA OR AUTHORITIES HAVING JURISDICTION.

IMPORTANT SAFETY INSTRUCTIONS

Do not make or alter any open holes in an enclosure of wiring or electrical components during kit installation. Not for use with dimmers. The end retrofit luminaire has been modified and can no longer operate the originally intended lamp. **Caution-Risk of Electric Shock:** Use in Dry and Damp Locations Only. **Risk of Electric shock:** Do Not Use Where Directly Exposed to Water. This device is not intended for use with emergency exit fixtures or emergency exit lights.

SECTION3-Installation Instruction

!!DANGER-RISK OF SHOCK-DISCONNECT POWER BEFORE INSTALLATION!!

1 Disconnect power

Fluorescent tube to be replaced

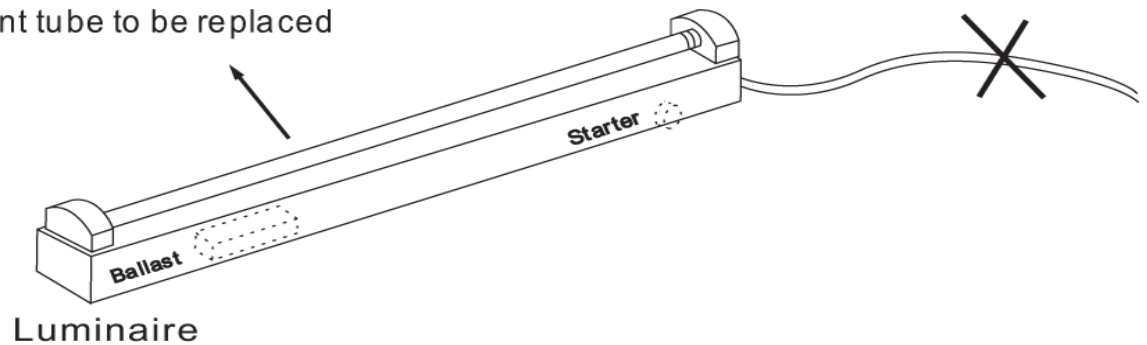

2 Remove fluorescent tube, ballast

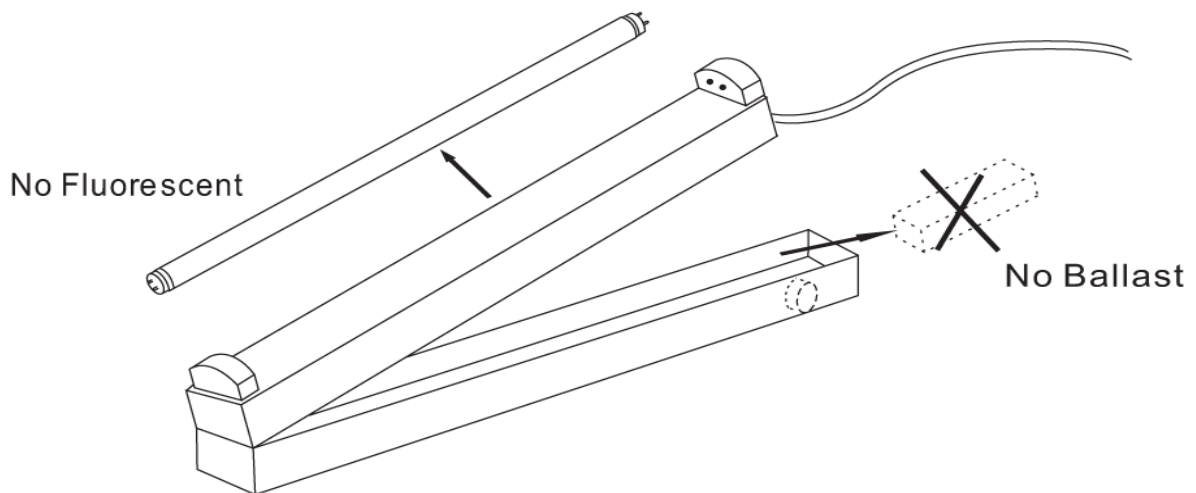

3 Principle of wire circle

1) Principle of wire circle

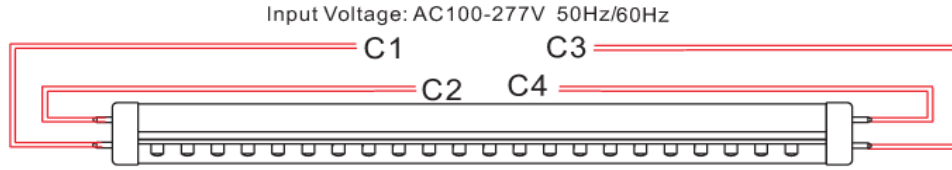

A. 55634

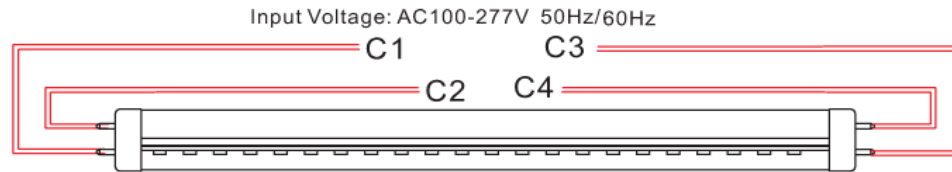

B. 78687

2) Luminaire connecting

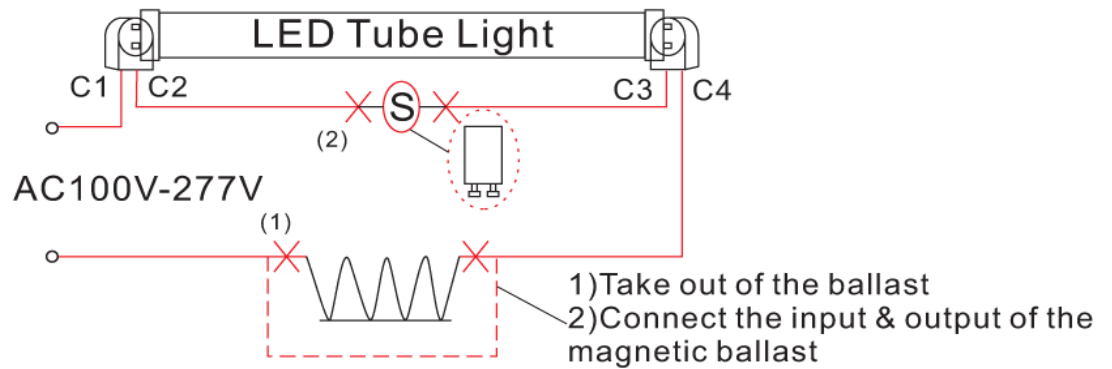

C. The Luminaire with magnetic ballast & starter

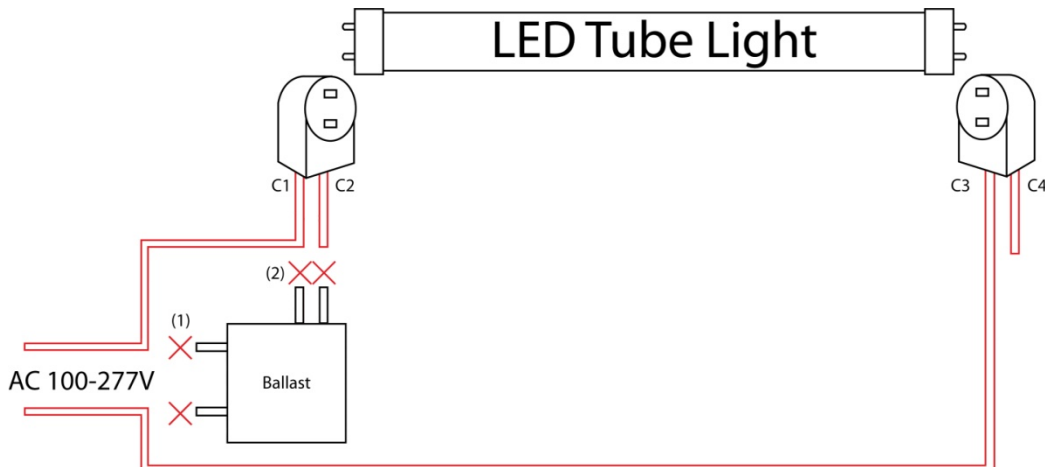

D. The Luminaire with Electronic Ballast

3.) Description

- (1) To make the tube light on power and work, wire L and wire N, should be separately connected to any one wire of C1, C2, C3, C4 (see above figure A, B, C, D).
- (2) The wire L and wire N can be separately connected to more than one wire from C1, C2, C3, and C4.
- (3) To avoid the risk of electric shock issue, do not connect the two wires L and N together.

4) Operating

- (1) Turn off power first, and take out of the shell in the luminary,
- (2) Show as in the above figure A, B, C, D. Cut off the wires as show (1)(2)(3) in figure C, D. And then connect the wires as the method expressing in above item 3) Description.
- (3) Use the electric rubberized fabric or pressing wire cap to enlase well all the power supply cord parts which were cut off, especially the end sides of power supply cord. This is to prevent circuit from shorting and electronic shocking.

5) Assemble the shell, install LED tube light, and power on.

4 Wiring according to one of the follow diagrams

Wiring Method 1-Two sides connecting

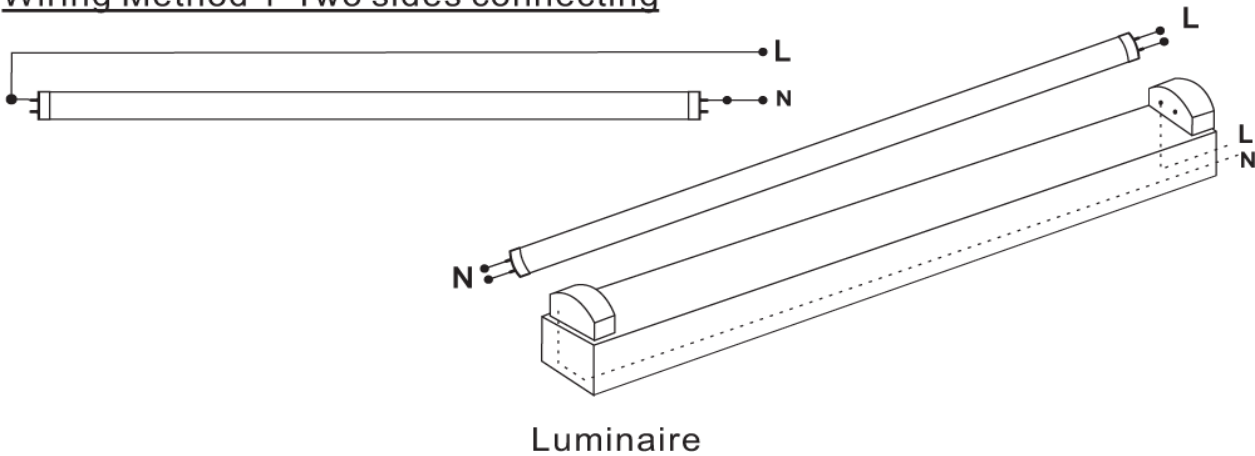

5 Install LED tube and Earth (Ground)

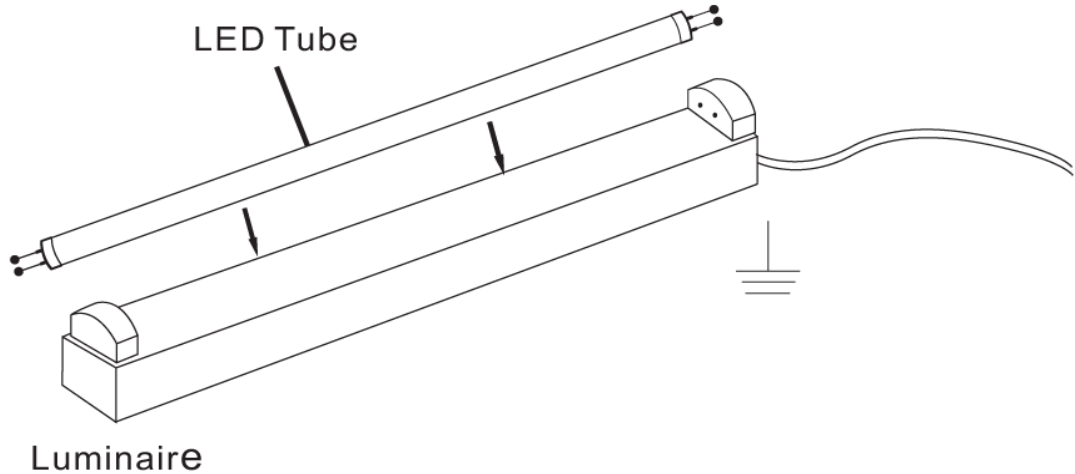

⚠ Ballast and Starter must be operated with the method as in step **3**
Adapt one of the three wiring methods in step **4** before installing LED tube

6 Connect to power

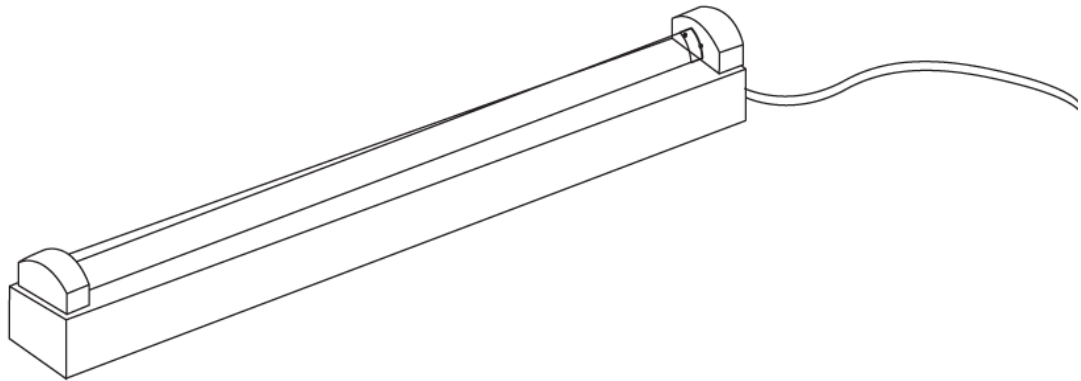

The luminaire has been modified and no longer operates Fluorescent Lamps.
These Kits, Replacement Label, and Installation instruction are provided with the LED Tube.
Use only, LEDLight.com models for lamp replacement

Website: www.LEDLight.com
Email: sales@LEDLight.com
Tel: (001)-877-283-5060
Fax: (001)-602-861-4088
Address: 12215 East Chandler Heights Rd. Chandler, AZ 85249